

GENERAL INFORMATION

THE UNIVERSITY

New Mexico State University (NMSU) is the state's land-grant university, serving the educational needs of New Mexico's diverse population through comprehensive programs of education, research, extension education, and public service. NMSU was founded in 1888 as Las Cruces College and later renamed New Mexico College of Agriculture and Mechanic Arts. In 1960, the constitution of New Mexico formally recognized the institution as NMSU. Throughout its history, the university has preserved many of the traditions of its land-grant origin while also increasing emphasis on the fine arts, humanities, social and natural sciences. Today, NMSU is a major institution of higher education.

ADMISSIONS

A student may be accepted for undergraduate admission to NMSU as (1) a regular student or (2) a nondegree student under the policies and conditions as set forth in this section.

REGULAR ADMISSION (FIRST TIME ANY COLLEGE)

Requirements for admission as a regular student include the following:

- Formal application for admission, accompanied by a \$20 nonrefundable application fee.
- An official transcript of the student's high school credits is to be sent directly from the high school to the Admissions Office.
- Official results of the American College Testing Program (ACT) or Scholastic Aptitude Test (SAT) are to be sent directly from the Testing Centers to the Admissions Office.
- Qualifications for undergraduate admission to NMSU are as follows:
- Graduation from any state high school or academy in the United States accredited by a regional accrediting association or approved by a state department of education or state universities.
- Meet the minimum high school unit requirements listed below and have a high school grade-point average of at least 2.0 and ACT standard composite score of at least 20; or high school grade-point average of at least 2.5; or ACT standard composite score of at least 21.

The following high school unit requirements became effective with the class of 1991:

English	4 units*
Science	2 units beyond general science
Mathematics	3 units**
Foreign languages or fine arts	1 unit

* Must include at least 2 units of composition, one of which must be a junior or senior-level course.

** From algebra I, algebra II, geometry, trigonometry, or advanced math.

- First-time freshmen who do not meet the regular admission requirements will be refused admission and can appeal to the Admission Appeals Committee. For more information, contact the Office of Admissions.

Provisional Admission

A new student, other than a transfer student, who does not meet requirements for regular admission may be admitted under the provisional program. To be admitted to provisional status, students must: 1) have a minimum high school grade-point average of 2.25 and ACT composite score of 19 and meet all the minimum high school unit requirements listed above *or* (2) have met all but one of the minimum high school units listed above *and* (a) have a high school grade point average of at least a 2.50 *or* (b) have a high school grade point average of a 2.00 and an ACT standard composite score of 20 *or* (c) have an ACT standard composite score of at least 21. Such a student must take at least 6, but not more than 12 credits, in a regular semester, and at least 3, but not more than 6 credits, in a single summer session.

A provisional student earning a 2.0 grade-point average or higher in at least the minimum number of credits as stated above will be granted regular admission. Should the provisional student earn less than a 1.0 grade-point average in the first semester, further attendance will be denied.

A provisional student earning less than a 2.0 grade-point average, but more than a 1.0 grade-point average in at least the minimum number of credits as stated above, in the first semester may continue for one additional semester. However, a provisional student who fails to attain a 2.0 grade-point average during the second semester will be denied further attendance.

Home School Students

Students enrolled in a home school program may be accepted to NMSU if they meet the requirements for regular or provisional admission as previously stated. In addition, the home school educator must submit a transcript or document that lists the courses completed and grades earned by the student and also indicates the date the student completed or graduated from the home school program. For financial aid eligibility see Major Scholarships for Entering Freshman 2006 in the Financial Aid section of this chapter.

Basic Academic Skills and Admission

In order to succeed at their college studies, entering students are required to have basic skills in mathematics and writing befitting the university

ACCREDITATION

New Mexico State University has been accredited since 1926 by The Higher Learning Commission and is a member of the North Central Association (NCA may be contacted at 30 North LaSalle St., Suite 2400, Chicago, IL 60602-2504 and (800) 621-7440.) The university was accredited in 1954 by the American Association of University Women. The university's teacher preparation program, which involves several colleges and which is directed by the College of Education, was accredited in 1962 by the National Council for the Accreditation of Teacher Education.

The Division of Student Services has two accredited departments as well. The Counseling Center is fully accredited by the International Association of Counseling Services (IACS), and the Student Health Center is accredited by the Accreditation Association for Ambulatory Health Care (AAAHC).

Various academic departments and programs are accredited separately by independent accreditation agencies. These may be found at the beginning of each college chapter.

environment. Students are evaluated using ACT test scores or diagnostic testing at the time of registration to determine basic academic competency. Based upon this evaluation, the university will require entering students to correct deficiencies by completing course work in English and mathematics before enrolling in courses numbered 300 and above. Specific regulations regarding this policy are described later in this chapter under "Basic Academic Skills."

Application Deadlines

Applications for admission as a regular student should be sent to the Admissions Office at least 30 days before the beginning of the regular semester or summer session for which the student intends to enroll. NMSU programs that have different deadlines for application are:

NursingMarch 1 (fall semester)
August 1 (spring semester)

Admission by GED

Any student who has successfully completed the GED may apply for admission. The admission will depend upon satisfactory scores on the General Educational Development (GED) test and the American College Testing Program (ACT) test. If the student's original high school class was 1991 or later, an official high school transcript needs to be submitted to determine if the above listed high school unit requirements were completed.

Early Admission for High School Students

Currently enrolled high school students of superior academic ability may be admitted as early admission students prior to high school graduation. Documents to be submitted include regular application for admission, recommendation of the high school principal/counselor, parental permission, high school transcript, and ACT scores.

Requirements to be admitted to the program are a high school grade point average (GPA) of 3.0 or an ACT of 21, and an interview with the director of admissions.

Western Undergraduate Exchange Program (WUE)

The Western Undergraduate Exchange Program (WUE) offers students a reduced tuition rate. Students from participating WUE states, who are eligible for regular admission to NMSU, will be charged 150% of regular resident tuition (i.e., 50% more than resident tuition), plus any fees that all students are required to pay. WUE states include Alaska, Arizona, Colorado, Hawaii, Idaho, Montana, Nevada, New Mexico, North Dakota, Oregon, South Dakota, Utah, Washington and Wyoming. Contact the Office of Financial Aid and Scholarship Programs for more information.

Readmission (Degree Seeking)

Former students of NMSU, or of one of its branches, who have been out of school for a regular semester or longer are required to make formal application for readmission. Applications should be submitted to the Admissions Office at least 30 days before the opening of the semester or summer session for which the student plans to enroll.

A student who has attended other institutions during an absence must have official transcripts forwarded directly to the Admissions Office by the registrar of each institution and must be eligible to return to the college or university last attended. Transcripts must be received prior to the date of registration. Admission status at the time of readmission will normally be determined by previous NMSU academic standing. However, academic performance at other institutions attended during the applicant's absence from NMSU may be taken into consideration in determining the student's admission status.

NMSU Graduation and Retention Rates

The graduation rate for first-time freshmen who enrolled full time in fall 1997 is 46% after six years, based on an entering cohort of 1,694 students. The one-year retention rate for first-time freshmen who enrolled full time in fall 2002 is 72% based on an entering cohort of 1,977 students.

TRANSFER STUDENTS

Transfer students from other colleges or universities may be accepted for undergraduate studies if they have at least a 2.0 cumulative grade-point average and are eligible to return to the college or university last attended. Transfer students who would not have met admission requirements as first-time freshmen must have completed at least 30 graded credits to be considered for admission.

Transcripts

The transfer student must have official transcripts forwarded directly to the Office of Admissions by the Registrar of each college or educational institution previously attended. The ACT may be required of students who have not earned credit for the first semester of college English. A student who conceals the fact that he or she has attended another college or university, and who has not had the registrar submit a transcript for each institution whether or not credit was earned, will be subject to immediate suspension. Transcripts must be received before the date of registration.

Transfer of Credits at NMSU

NMSU evaluates courses from postsecondary institutions that are regionally accredited or are candidates for regional accreditation. Transfer students will receive full credit for course work completed with a grade of C or better, provided the classes are similar or equivalent to courses offered at NMSU. A transfer student may, on the basis of an evaluation of his or her transcripts, receive credit for courses taken at other institutions in which a grade of D was received. However, NMSU does not accept the transfer of courses with D grades that satisfy basic academic competency (basic skills) in English and mathematics. And NMSU will not accept transfer credit for 4 credit basic skills courses (such as ENGL 111G and CCDD 114) when the incoming course carries less than 3 credit hours. Also, colleges or departments may choose to accept only courses graded C or higher in their programs for both transfer and native students. Any lower-division course from another institution receiving transfer credit from NMSU at the 300 or above level will still count as a lower-division course. Transcripts will be reevaluated when students transfer from one NMSU college to another.

Each college determines which transferred courses are applicable toward a degree or a minor.

Grades earned in courses taken at other institutions are not included in the calculation of the NMSU GPA, except for grades earned by approved National Student Exchange students.

Community/Junior College Transfers

Community/junior college transfer students may be admitted and classified on the basis of acceptable credits earned at a two-year institution. However, transfer students are subject to the same graduation requirements as other NMSU students, including the required minimum number of credits from courses numbered 300 or above and the requirement that the last 30 credits must be earned through this university.

Evaluation of Transfer Credits

Once a student has been admitted to NMSU, an evaluation of credits on a course-by-course basis is submitted to the college to which the student is admitted for an evaluation by the student's academic dean. The student's academic dean approves those transfer courses that are acceptable toward a degree or a minor.

Credits from nonaccredited institutions may be evaluated by the student's academic dean after the student has completed two semesters in full-time status with satisfactory grades.

Currently enrolled students must obtain prior approval from their academic dean before work taken at another institution may apply toward meeting graduation requirements.

Religious Center Courses in Religion

Courses in religion, offered by the various religious centers through higher educational institutions with which they are affiliated, are open to all students, and these or similar courses from other universities may be transferred for credit to this university. If a student wishes to have earned credits transferred to NMSU, the following procedures must be observed:

- Obtain written approval from the academic dean prior to registration for the course at the religious center
- Count the credit in the course as part of the total semester load
- Following completion of the course, request that the institution granting the credit send a transcript of the credit to the registrar at NMSU

Registration for these courses in religion is separate from NMSU's registration and is conducted by the religious center offering the course.

Not more than 6 credits in such courses may be transferred to NMSU.

Transferring Courses to Fulfill the New Mexico General Education Common Core

During the 2005 New Mexico Legislative session, Senate Bill 161, consistent with requirements of state law (Chapter 224 of the Laws of New Mexico,

1995 as amended) was signed into law to further enhance and facilitate the articulation of general education courses among New Mexico’s colleges and universities. In accordance with policies established by the New Mexico Higher Education Department, designated general education core courses successfully completed at any regionally accredited public institution of higher education in New Mexico are guaranteed to transfer to any New Mexico public institution. Students who have decided on a major and/or an institution at which to complete their studies should consult with an academic advisor at that particular institution to determine the most appropriate course selections. Students enrolling for the first-year of study at a New Mexico college or university and considering possible transfer into a certificate and/or degree program at another institution are encouraged to take the courses approved for transfer during their freshman and sophomore year of study.

The core matrix of approved courses guaranteed to transfer and meet general education requirements at any New Mexico college or university can be found on the New Mexico Higher Education Department web site at www.hed.state.nm.us/colleges/matrix.asp. Courses are listed by institution, whether university or community college, under each of the five general education areas. The approved courses for New Mexico State University are listed below with their equivalent New Mexico Common Course Number as applicable.

The New Mexico General Education Common Core

(New Mexico Common Course Numbers are in parenthesis where applicable.)

Area I: Communications (Select 9 credits)

ENGL 111G (ENGL 1114), Rhetoric and Composition	4
ENGL 203G, Business and Professional Communication.....	3
ENGL 211G, Writing in the Humanities and Social Sciences.....	3
ENGL 218G (ENGL 2113), Technical and Scientific Communication.....	3
ENGL 311G, Advanced Composition.....	3
ENGL 318G, Advanced Technical and Professional Communication	3
COMM 253G (ENGL 1113), Public Speaking	3
COMM 265G (ENGL 1213), Principles of Human Communication.....	3

Area II: Mathematics (Select 3 credits)

MATH 121, (MATH 1113), College Algebra	3
MATH 142G, Calculus for the Biological and Management Sciences I.....	3
MATH 210G, Math Appreciation	3

Area III: Science, with Laboratory (Select 8 credits)

BIOL 110G, Contemporary Problems in Biology	4
BIOL 111G/111L (BIOL 1111/1113), Natural History of Life	4
BIOL 211G/211L (BIOL 1211/1213), Cellular and Organismal Biology	4
CHEM 110G (CHEM 1114), Principles and Applications of Chemistry	4
PHYS 110G, Great Ideas of Physics	4
GEOL 111G (GEOL 1114), Survey of Geology.....	4
ASTR 110G (ASTR 1114), Introduction to Astronomy	4
ASTR 105G, The Planets	4

Area IV: Social/Behavioral Sciences (Select 6-9 credits)

ECON 251G (ECON 2113), Principles of Macroeconomics	3
ECON 252G (ECON 2123), Principles of Microeconomics.....	3
GOVT 110G (POLS 1113), Introduction to Political Sciences.....	3
PSY 201G (PSY 1113), Introduction to Psychology.....	3
SOC 101G (SOC1 1113), Introduction to Sociology.....	3
ANTH 120G, Human Ancestors	3
ANTH 125G (ANTH 2113), Introductions to World Cultures.....	3
ANTH 201G (ANTH 1113), Introduction to Anthropology.....	3

Area V: Humanities and Fine Arts (Select 6-9 credits)

HIST 101G (HIST 1053), Roots of Modern Europe	3
HIST 102G (HIST 1063), Modern Europe.....	3
HIST 201G (HIST 1113), Introduction to Early American History.....	3
HIST 202G (HIST 1123), Introduction to Recent American History.....	3
PHIL 101G, The Art of Wondering	3
PHIL 201G (PHIL 1113), Introduction to Philosophy	3
ART 101G (ARTS 1113), Orientation in Art.....	3
MUS 101G (MUSI 1013), Introduction to Music.....	3
THTR 101G (THTR 1013), Introduction to Theater.....	3
any 100-200 level literature course.....	3

New Mexico Common Course Numbers

The course prefix and number that appear in parenthesis above next to the NMSU course number is the New Mexico Common Course Number. This

is a four alpha/four numeric set of uniform course designations that serve as a single reference point for courses taught throughout the state that share substantially equivalent content. Courses bearing this designation are part of a statewide equivalency table that cross-references the institutional course and number with the universal “common course number” creating an easy one-to-one match.

Students may find the New Mexico Common Course Number listed in crosswalks, degree outlines, transfer guides and in course descriptions in college catalogs and web sites. Simply put, the common course number connects equivalent courses at multiple institutions ensuring students that the course will transfer to the receiving institution and meet degree requirements as if it were taken on that campus.

The New Mexico Common Course Number has an alpha prefix that identifies readily to the subject area. The four digits in the number represent the specific course in that subject area with each digit having significance as demonstrated below:

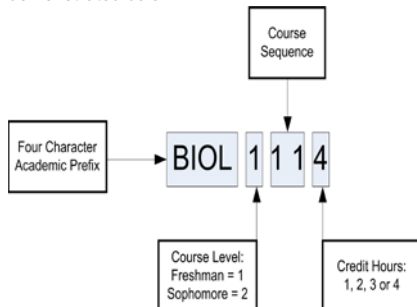

Transferring Courses Within Degree Programs

To facilitate the transfer of courses within certain degree programs, New Mexico colleges and universities have collaborated to develop transferable discipline modules. These are made up of an agreed upon number of hours and courses. When discipline module courses are taken in addition to the 35-hour general education core, the total number of hours in a transfer module are approximately 64.

For information on the transferable discipline module for Business, see the College of Business chapter. For information on the transferable discipline module for Early Childhood Education, see the College of Education chapter.

Inter-Institutional Transfer Guides and Catalogs

Students who have selected a field of study and/or the institution where they wish to graduate are advised to consult the transfer guide or catalog for that institution for more current and detailed advice to guide their course selection. Formal published transfer guides between most New Mexico community colleges and NMSU are available at the community college and the appropriate NMSU college advisement center.

Student Responsibility

New Mexico’s colleges and universities have collaborated to produce guides to assist students who plan to transfer before completing a program of study. Course modules are designed to help students select courses carefully so that they may transfer with little or no loss of credit. However, planning for effective transfer within maximum efficiency is ultimately the student’s responsibility. Responsible transfer planning includes early and regular consultation with the intended degree-granting institution to assure that all pre-transfer course work will meet the requirement of the of desired degree.

Complaint Procedure for Transfer Credit Appeal

All New Mexico public post-secondary institutions are required to establish policies and practices for receiving and resolving complaints from students or from other complainants regarding the transfer of course work from other public institutions in the state. A copy of NMSU’s complaint policy may be obtained from the Office of the Registrar or from the Deputy Secretary for Academic Affairs, Higher Education Department, New Mexico School for the Deaf Campus, 1068 Cerrillos Road, Santa Fe, New Mexico 87505-1650.

National Student Exchange (NSE)

Courses transferred back to NMSU by students participating in the National Student Exchange (NSE) Program will be evaluated as NMSU courses and recorded on the student’s academic record. All computable grades earned will be included in calculating the student’s cumulative grade-point average.

Visiting Undergraduate Students

Students planning to enroll for a summer or semester who expect to transfer credits back to their home institution must have a letter sent from that institution's registrar to the NMSU Admissions Office indicating that they are in good standing at the present institution. If at a later time the student wishes to matriculate as a full-time regular student at NMSU, all requirements for regular admission must be met.

Out-of-State Students and Legal Jurisdiction

By applying for admission/enrollment, both the student and parents agree that New Mexico law prevails and all litigation will be in federal court in New Mexico or in state court in Doña Ana County, New Mexico.

NONDEGREE ADMISSION

Nondegree admission is designed to meet the needs of mature, part-time students who do not wish to pursue a degree at this university. *Courses taken in this status may not be used to meet university admission requirements.*

Students on nondegree status are not eligible to receive financial aid or student employment; nor are they eligible to participate in student government or intercollegiate athletics; nor are they eligible to receive benefits from any veterans' program.

Students interested in using nondegree credit for initial teacher certification or recertification in a new field need to contact the College of Education. Transcripts from previous institutions, high school, and/or results of college entrance exams may be required to assure readiness for university-level courses.

Nondegree students are subject to the same university regulations as regular students.

Nondegree students may not transfer more than 30 credits from this status to any undergraduate degree program.

Admission requirements include a nondegree application and \$20 application fee.

Nondegree Status

Students who have been denied admission to the Graduate School may qualify for admission as provisional graduate students by enrolling as nondegree students in a college of their choice, and by completing 9 credits or more of graduate work (exclusive of directed readings and independent study) with a grade-point average of 3.0 or above. It should be noted that enrollment in some graduate-level courses is restricted to students accepted into specific programs. Academic advising for nondegree students should be obtained from the department or program of interest to the student. After meeting this requirement, upon receipt of a readmission application the student's records will be resubmitted to the department of choice for a decision as to admission. Also, non-NMSU graduates whose graduate application packet is incomplete may apply as a nondegree student in order to register for classes.

Not more than three courses totalling 9 credits or fewer earned in nondegree status at NMSU may be transferred to a graduate program. NMSU does not recognize graduate credit for nondegree work from institutions other than the University of New Mexico (UNM), from which 6 credits may be accepted with the approval of the appropriate department, the college dean, and the graduate dean. Therefore, any student who has previously been accepted and enrolled in the Graduate School at NMSU should not change to a nondegree program unless it is the intention never to pursue further studies leading to an advanced degree.

Changing from Nondegree Status

A nondegree student in good academic standing at NMSU may apply for change of status from nondegree to regular. Requirements for regular admission must be met.

Auditing Courses

Students who wish to audit courses may do so as nondegree students with the consent of the instructor, provided the facilities are not required for regular students. Regular students may also audit courses, but audited courses are not counted in determining maximum course loads, except for students on probation or graduate students.

FOREIGN STUDENTS

The general policies of the university as outlined in this catalog apply to foreign as well as domestic students. However, some special policies are necessitated by federal laws applicable only to foreign students.

A foreign student is any individual attending NMSU while present in the United States on a non-immigrant student visa. Legal immigrants or refugees must present documentation of their status either to Admissions or to the International Programs (IP) Office.

U.S. Citizenship and Immigration Services (USCIS)

Some of the more important rules as established by the United States Department of Homeland Security are

1. Each student must maintain full-time student status for both the fall and spring semesters.
2. Foreign students may not work off campus without authorization. On-campus employment may be authorized under certain conditions.
3. All foreign students must maintain an up-to-date record in the IP Office. This record must indicate the student's current living address and local phone number.
4. Prior to admission, a prospective foreign student must demonstrate the following:
 - Academic ability to succeed in the chosen course of study;
 - Adequate financial support to complete the chosen course of study; and
 - Adequate command of the English language to maintain legal status as a full-time student for the fall and spring semesters.

UNIVERSITY PROCEDURES FOR FOREIGN STUDENTS

Scholastic Ability

1. Prospective undergraduates must have completed a minimum of 12 years' schooling and/or submit official diploma or completion certificate.
2. Official transcripts showing the classes taken and grades earned for the school years 10, 11, and 12 must be submitted. No hand-carried documents will be accepted unless received in a sealed envelope.
3. The scholastic average for the last three years of high school must be equivalent to 2.5. Foreign students are not admitted on a provisional or probationary basis.
4. Graduation from a high school in the United States does not automatically qualify a foreign student for admission to NMSU. The student must also submit official transcripts from his or her foreign secondary school.

Financial Support

1. Each prospective foreign student must submit a current financial support document with his or her application.
2. This document must show that (a) the person providing the financial support has the necessary funds, and (b) the funds can be transferred from the student's home country to the United States.

No financial aid is available from NMSU. The university reserves the right to demand advance deposit of funds for any period deemed reasonable prior to granting admission. A foreign national can never qualify for residency and must pay nonresident fees.

English Language Proficiency

NMSU requires a score of 500 (paper-based)/173 (computer-based)/61 (internet-based) or better on the Test of English as a Foreign Language (TOEFL) for all foreign students, both nondegree and degree seeking. Foreign students may also demonstrate English proficiency by satisfactorily completing NMSU's Intensive English as Second Language programs. A waiver of the TOEFL requirement may be considered for

- 1) Students who are native speakers of English.
- 2) Students completing high school in the United States who (a) have attended the high school for at least two full semesters and (b) have scored in at least the 75th percentile in English on the ACT.
- 3) Students transferring from a junior college, or university in the United States who have earned a minimum of 30 acceptable semester credits (45 acceptable quarter credits) with a GPA of 2.5 or better. "Acceptable credit" means classes that require a high proficiency in both written and oral English.